



Bulletin HY11-5715-669/UK

Operation Manual Series D*FB / D*1FB with Integrated Electronics

D*FB Design ≥ 12

D*1FB Design ≥ 10

Proportional Directional Control Valve



**Parker Hannifin
Manufacturing Germany GmbH & Co. KG**

Hydraulic Controls Division Europe

Gutenbergstr. 38

41564 Kaarst, Germany

Tel.: (+49) 181 99 44 43 0

E-mail: infohcd@parker.com

Copyright © 2013, Parker Hannifin Corp.

Note

This document and other information from Parker-Hannifin Corporation, its subsidiaries and authorized distributors provide product or system options for further investigation by users having technical expertise.

The user, through its own analysis and testing, is solely responsible for making the final selection of the system and components and assuring that all performance, endurance, maintenance, safety and warning requirements of the application are met. The user must analyze all aspects of the application, follow applicable industry standards, and follow the information concerning the product in the current product catalog and in any other materials provided from Parker or its subsidiaries or authorized distributors.

To the extent that Parker or its subsidiaries or authorized distributors provide component or system options based upon data or specifications provided by the user, the user is responsible for determining that such data and specifications are suitable and sufficient for all applications and reasonably foreseeable uses of the components or systems.

Chapter	Page
1. Introduction	4
Order Code D*FB	4
Order Code D*1FB	5
Name Plate Example	6
Block Diagram of Integral Electronics	6
Characteristics of Valve Driver	6
Technical Data	7
Signal Flow Diagram	8
2. Safety Instructions	9
Symbols	9
Marking, Name Plates	9
Work at the Valve	9
3. Important Details	9
Intended Usage	9
Common Instructions	9
Liability	9
Storage	9
4. Mounting / Installation	10
Scope of Supply	10
Mounting	10
Operation Limits	10
Pressure Fluids	10
Electrical Connection	11
Electrical Interfacing	12
5. Operation Instructions	18
ProPxD parameterizing software	18
Screenshot	18
Hardware requirements	18
Cable Specification	18
Parametrizing connection	19
Parametrizing cable	19
Program Installation	19
Software Operating	19
Parameter overview for basic mode	21
Individual Description of Basis-Parameters	22
Parameter overview for expert mode	23
Individual Description of Expert Parameters	23
Error messages	24
Air Bleeding of Hydraulic System	25
Filter	25
Flushing	25
6. Maintenance	25
7. Trouble Shooting	26
8. Accessories / Spare Parts	27
Accessories	27
Spare Parts	27

Operation Manual

1. Introduction

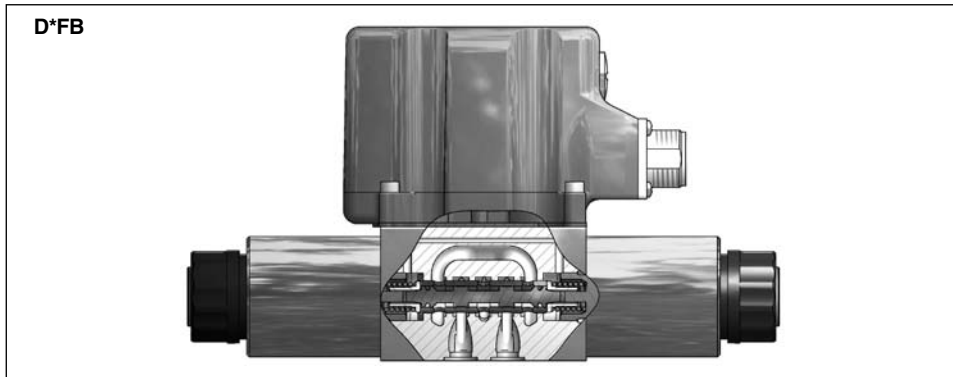

Ordering Code D*FB

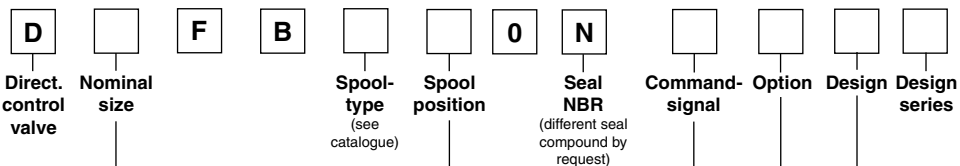

Code	Nominal size
1	NG06 / CETOP 3
3	NG10 / CETOP 5

Code	Design
0	Spool/sleeve design
3	Spool/body design

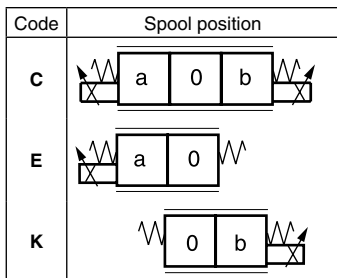

Code	Command signal	Function	Connection	Option
F0	0...+/-10V	0...+10V > P-A	6 + PE	Pot.-supply
S0	4...20mA	12...20mA > P-A	6 + PE	-
W5 ¹⁾	0...+/-10V 4...20mA	0...+10V > P-A 12...20mA > P-A	11 + PE	Pot.-supply & command preset channel

¹⁾ Factory set +/-10V

Ordering Code D*1FB

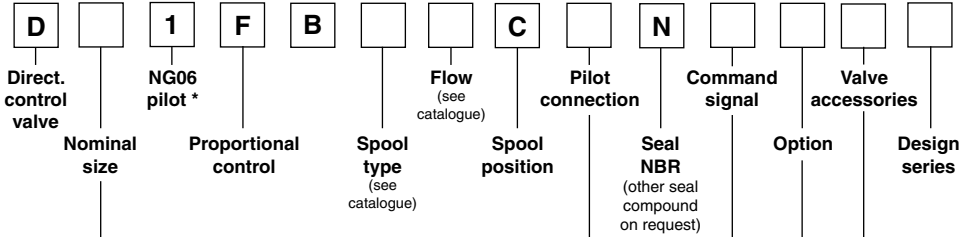

Code	Nominal size
3	NG10 / CETOP05
4	NG16 / CETOP07
9 ¹⁾	NG25 / CETOP08
11	NG32 / CETOP10

¹⁾ with enlarged connections
 Ø 32 mm

Code	Inlet	Drain
1	internal	external
2	external	external
4	internal	internal
5	external	internal

Code	Command signal	Function	Connection	Option
F0	0...±10V	0...+10V > P-B	6 + PE	Pot.-supply
M0	0...±10V	0...+10V > P-A	6 + PE	Pot.-supply
S0	4...20mA	12...20mA > P-A	6 + PE	—
G0	0...±20mA	0...+20mA > P-B	6 + PE	—
W5	0...±10V 4...20mA	0...+10V > P-A 12...20mA > P-A	11 + PE	Pot.-supply & command preset channels

Code	Valve accessories
0	Standard
8	Monitor switch

* as D1FV* separately available

Name Plate Example

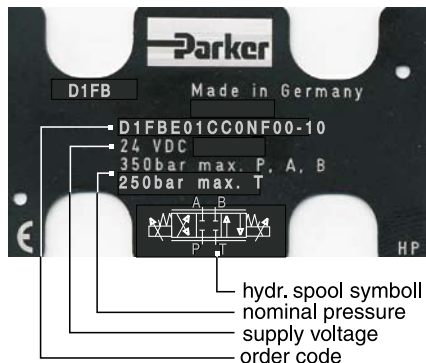

Block Diagram of Integral Electronics Code F0/M0 (6+PE)

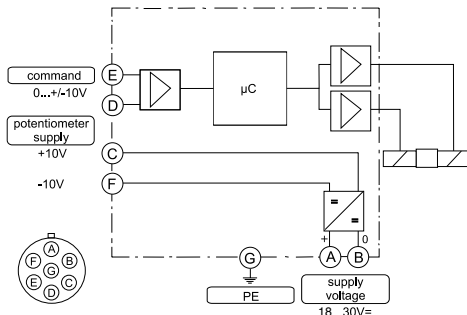

Parker D*FB/D*1FB proportional directional control valves have an integral electronic and requires only one sole electrical common for the control system. Different flow sizes, as well as command signal options are available to achieve an optimal adaption for different applications.

Characteristics of Valve Driver

The described integral electronic driver combines all necessary functions for the optimal operation of the valve. The most important features are:

- digital circuit design
- high dynamic constant current solenoid control
- differential input stage with various command signal options
- four quadrant ramp function
- MIN adjustment for deadband compensation
- MAX adjustment to match the command signal span to the valve operating range
- optional reference outputs +/- 10V for potentiometer supply
- optional four parametrizable preset recall channels
- standard central connection
- compatible to the relevant European EMC-standards
- comfortable interface program

Code S0/G0 (6+PE)

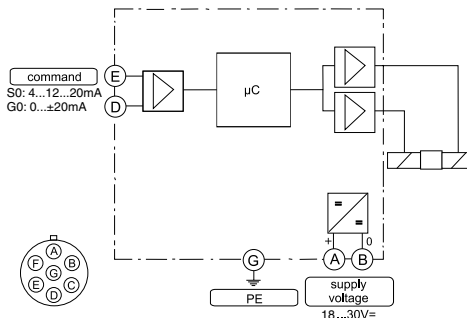

Code W5 (11+PE)

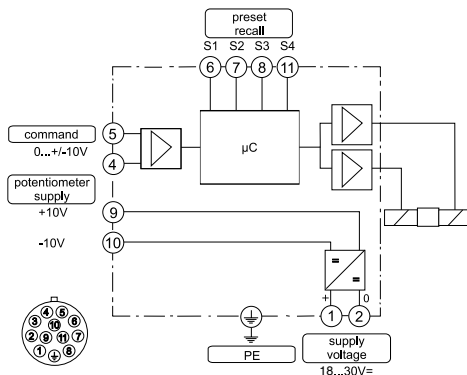

Technical Data

General		
Model		Proportional directional control valve, direct operated (D*FB), pilot operated (D*1FB)
Drive		Proportional solenoid
Mounting Pattern		NG6 (CETOP 3) / NG10 (CETOP 5) NG16 (CETOP 7) / NG25 (CETOP 8) / NG32 (CETOP 11)
Installation Position		Any
Hysteresis	D1FB*0/D3FB*0 [%] D3FB*3/D*1FB [%]	< 4 < 5
Ambient Temperature Range	[°C]	-20...+60
Protection Class		NEMA 4 (IP 65) acc. EN 60529
Vibration Strength	[G]	10 Sinus 5...2000 Hz acc. IEC 68-2-6 30 Random noise 20...2000 Hz acc. IEC 68-2-36 15 Shock acc. IEC 68-2-27
Weight	[kg]	NG6: 3 / NG10: 7 / NG16: 11 / NG25: 19.5 / NG32: 61
Hydraulic		
Fluid		Hydraulic oil according to DIN 51524...535, other on request
Viscosity permitted	[cSt]/[mm ² /s]	20...400
Fluid Temperature	[°C]	-20...+60 (NBR: -25...+60)
Filtration		ISO 4406 (1999); 18/16/13
Operating Pressure max. (D*FB)	[bar]	350 for ports P, A, B / 210 for port T
Pilot oil intern (D*1FB):	[bar]	350 for ports P, A, B, X / 185 for T, Y
Pilot oil extern (D*1FB):	[bar]	350 for ports P, A, B, T, X / 185 for Y
Electrical		
Duty Ratio	[%]	100
Supply Voltage	Us [VDC]	18...30, ripple < 5% eff., surge free
Current Consumption max.	[A]	D1FB: 1.5 / D3FB: 2.0 / D*1FB: 1.5
Pre-Fusing	[A]	D1FB: 2.0 / D3FB: 2.5 / D*1FB: 2.0
Potentiometer supply	Up [V]	± 10 / ± 5 % max. 10 mA
Command Signal Options	Uc [V] Ic [mA]	Codes F0, M0, W5: +10...0...-10, ripple < 0.01 % eff., surge free, Ri = 100 kOhm Codes S0 & W5: 4...12...20, ripple < 0.01 % eff., surge free, Ri = 200 Ohm < 3.6 mA = enable off, > 3.8 mA = enable on (acc. NAMUR NE43) Code G0: +20...0...-20, ripple < 0.01 % eff., surge free, Ri = 200 Ohm
Differential Input Voltage max.	[V]	Codes F0, M0, S0, G0: 30 for terminal D and E against PE (terminal G) 11 for terminal D and E against 0V (terminal B) Code W5: 30 for terminal 4 and 5 against PE (terminal PE) 11 for terminal 4 and 5 against 0V (terminal 2)
Channel Recall Signal	Uch [V]	0...2.5: Off / 5...30: On / Ri = 100 kOhm
Adjustment Ranges	Min [%] Max [%] Ramp [s]	0...50 50...100 0...32.5
Interface		RS 232C, parametrizing connection 5pole
EMC		EN 61000-6-2, EN 61000-6-4
Central Connection		Codes F0, M0, S0, G0: 6 + PE acc. EN 175201-804 Code W5: 11 + PE acc. EN 175201-804
Cable Specification	[mm ²]	Codes F0, M0, S0, G0: 7 x 1.0 (AWG16) overall braid shield Code W5: 11 x 1.0 (AWG16) overall braid shield
Cable Length max.	[m]	50

Signal flow diagram

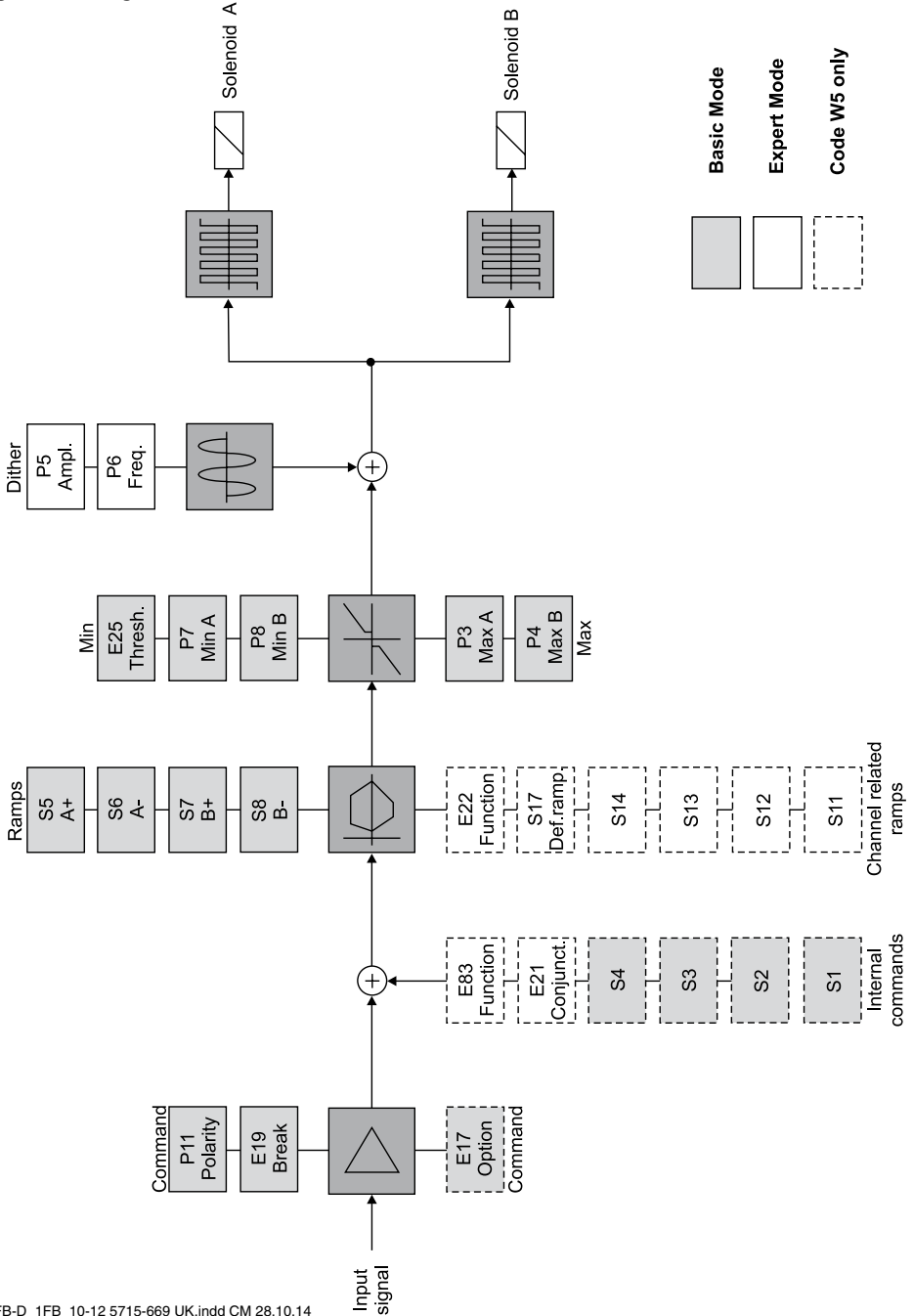

2. Safety Instructions

Please read the operation manual before installation, startup, service, repair or stocking! Paying no attention may result in damaging the valve or incorporated system parts.

Symbols

This manual uses symbols which have to be followed accordingly:



Instructions with regard to the warranty



Instructions with regard to possible damaging of the valve or linked system components



Helpful additional instructions

Marking, Name Plates

Instructions applied on the valve, i.e. wiring diagrams and name plates, must be observed and maintained legibly.

Work at the Valve

Workings in the area of installation, commissioning, maintenance and repair of the valve may only be allowed by qualified personnel. This means persons which have, because of education, experience and instruction, sufficient knowledge on relevant directives and approved technical rules.

3. Important Details

Intended Usage

This operation manual is valid for proportional directional control valves D*FB/D*1FB series. Any different or beyond it usage is deemed to be as not intended. The manufacturer is not liable for warranty claims resulting from this.

Common Instructions

We reserve the right for technical modifications of the described product. Illustrations and drawings within this manual are simplified representations. Due to further development, improvement and modification of the product the illustrations might not match precisely with the described valve. The technical specifications and dimensions are not binding. No claim may resulting out of it. Copyrights are reserved.

Liability

The manufacturer does not assume liability for damage due to the following failures:

- incorrect mounting / installation
- improper handling
- lack of maintenance
- operation outside the specifications



Do not disassemble the valve! In case of suspicion for a defect please return the valve to the factory.

Storage

In case of temporary storage the valve must be protected against contamination, atmospheric exposure and mechanical damages. Each valve has been factory tested with hydraulic oil, resulting in protection of the core parts against corrosion. Yet this protection is only ensured under the following conditions:

Storage period	Storage requirements
12 months	constant humidity < 60% as well as constant temperature < 25°C
6 months	varying humidity as well as varying temperature < 35°C



Outdoor storage or within sea and tropical climate will lead to corrosion and might disable the valve!

4. Mounting / Installation

Scope of Supply

Please check immediately after receiving the valve, if the content is matching with the specified scope of supply. The delivery includes:

- valve
- operation manual

The central connector assembly as well as the parametrizing cable has to be ordered separately and are not included in the delivery.

 Please check the delivery immediately after receiving the shipment for apparent damages due to shipping. Report shipment losses at once to the carrier, the insurance company and the supplier!

Mounting

- Compare valve type (located on the name plate) with part list resp. circuit diagram.
- The valve may be mounted fix or movable in any direction.
- Verify the mounting surface for the valve. Unevenness of 0.01 mm/100 mm, surface finish of 6.3 µm are tolerable values.

 Keep clean valve mounting surface and work environment!

- Remove protection plate from the valve mounting surface
- Check the proper position of the valve ports and the O-rings.
- Mounting bolts:
D1FB: 4 pcs. M5x30
D3FB: 4 pcs. M6x40
D31FB: 4 pcs. M6x40
D41FB: 2 pcs. M6x55 / 4 pcs. M10x60
D91FB: 6 pcs. M12x75
D111FB: 6 pcs. M20x90
use property class 12.9, DIN 912

-  Parker offers bolt kits:
D1FB: BK375, D3FB: BK385, D31FB: BK385, D41FB: BK320, D91FB: BK360, D111FB: BK386
- Tighten the bolts crisscross with the following torque values:
D1FB: 7.6 Nm / D3FB: 13.2 Nm
D31FB: 13.2 Nm, D41FB: 13 (63) Nm, D91FB: 108 Nm, D111FB: 517 Nm

 Insufficient condition of the valve mounting surface might create malfunction! Incorrect mounting resp. bolt torque may result in abrupt leakage of hydraulic fluid on the valve ports.

Operation Limits

The valve may be operated within the determined limits only. Please refer to the "technical data" section as well as to the "characteristic curves" in the catalog.

 Follow the environmental conditions! Unallowable temperatures, shock load, aggressive chemicals exposure, radiation exposure, illegal electromagnetic emissions may result in operating trouble and may lead to failure! Follow the operating limits listed in the "specifications" table!

Pressure Fluids

The following rules applies for the operation with various pressure fluids:

 The above information serves for orientation and does not substitute user tests among the particular operating conditions. Particularly no liability for media compatibility may be derived out of it.

mineral oil		usable without restriction
HFA	oil-in-water emulsion	consultation required
HFB	water-in-oil emulsion	consultation required
HFC	aqueous solution (glycols)	consultation required
HFD	anhydrous fluids (Phosphor-Ester)	consultation required

 For detailed information concerning pressure fluids note VDMA-document 24317 as well as DIN 51524 & 51502.

Special gaskets may be available depending on the utilized fluid.
In case of insecurity please consult the factory.

Electrical Connection

The electrical connection of the valve takes place by one common cable, which is coupled to the integrated electronic driver by a central connector assembly.

The connection Codes F0/S0 requires a 6 + PE female connector EN 175201-804.

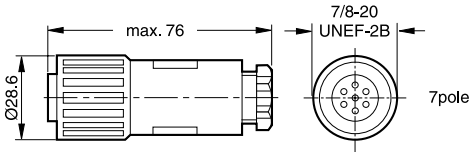

☞ The female connector has to be ordered separately under article nr. 5004072.

⚠ A female connector with metal housing is required! Plastic made models may create function problems due to insufficient EMC-characteristics.

The connecting cable has to comply to the following specification:

Cable type	control cable, flexible, 7 conductors, overall braid shield
Cross section	min. AWG16/1.0 mm ²
Outer dimension	8...12 mm
Cable length	max. 50 m

☞ For cable lengths > 50 m consult factory.

The connection cable is coupled to the female connector by solder joints.

Skinning lengths for the connecting cable:

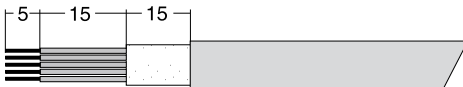

The connection Code W5 requires a 11 + PE female connector EN 175201-804.

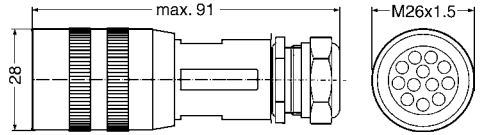

☞ The female connector has to be ordered separately under article nr. 5004711.

⚠ A female connector with metal housing is required! Plastic made models may create function problems due to insufficient EMC-characteristics.

The connecting cable has to comply to the following specification:

Cable type	control cable, flexible, 11 conductors, overall braid shield
Cross section	min. AWG16/1.0 mm ²
Outer dimension	12...15 mm
Cable length	max. 50 m

☞ For cable lengths > 50 m consult factory.

The connection cable is coupled to the female connector by crimp contacts.

Skinning lengths for the connecting cable:



☞ For the workmanlike termination of the crimp contacts the tool # 932 507-001 – supplier: Hirschmann – is required.

⚠ Do not disconnect cable socket under tension!

The shielding has to be assembled according to the outline below:

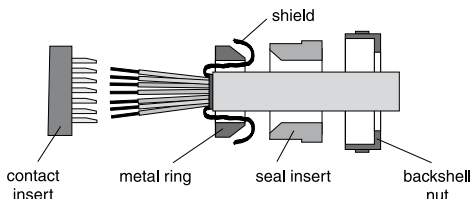

The backshell nut of the cable gland has to be tightened with a suitable tool. The target value for the tightening torque is 4 Nm. Tighten the cap nut with a torque of approx. 5 Nm after attaching the female connector on the socket outlet.

⚠ Incomplete tightening of backshell nut resp. cap nut may result in automatic release of the connection as well as degradation of the water tightness.

Follow the "instructions for use" for installation of female connectors made by other kind of brands!

⚠ The cable connection to the female connector has to take place by qualified personnel! A short between individual conductors resp. to the connector housing, bad soldering as well as improper shield connection may result in malfunction and breakdown of the valve.

⚠ The mounting surface of the valve has to be carefully tied to the earth grounded machine frame. The earth ground wire from the valve connecting cable as well as the cable shield have to be tied to the protective earth terminal within the control unit. It is necessary to use a low ohmic potential connection between control unit and machine frame to prevent earth loops (cross section AWG 6).

Electrical Interfacing

Supply Voltage:

The supply voltage for the valve has to cover the range of 18...30 V. The residual ripple may not exceed 5% eff.

⚠ The applied power supply must comply to the relevant regulations (DIN EN 61558) and must carry a CE-mark. The operating voltage for the valve must be free of inductive surges. Do not exceed the max. value of 30V! Non-observance of this rule may result in permanent damaging of the valve.

⚠ The increased inrush current of the valve should be considered when selecting the power supply. A stabilized power supply with overcurrent limiting feature should not be used. Due to the inrush current of the valve the current limit circuit may respond prematurely and create problems during energizing of the supply voltage.

⚠ The operation of the valve is blocked if the supply voltage polarity is interchanged.

⚠ Each valve requires a separate pre-fuse (rating: s. techn. data). Non-observance of this instruction may create irreparable damage of valve resp. incorporated system parts.

Wiring diagram of supply voltage
Code F0/M0/S0/G0 (6 + PE)

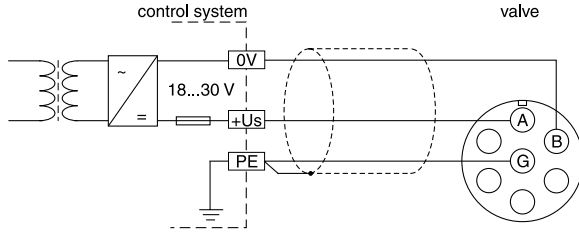

Code W5 (11 + PE)

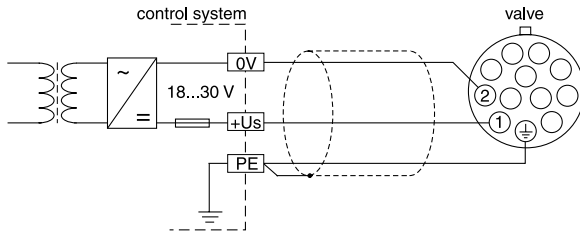

Command signal input:

The command signal for the valve will be connected to the difference signal input of the electronic driver. The solenoid current behaves proportional to the command signal amplitude. Different versions of command signal processing are available, depending on the valve type. These are described below: For the function description is assumed as signal reference (0V):

Code F0/M0/S0/G0: pin E, Code W5: pin 5

☞ Details are shown from the technical specifications.

⚠ The command input signal needs to be filtered as well as free of inductive surges and modulations. Due to the sensitivity of the valve a high signal quality is recommended, this will prevent malfunction.

⚠ Incorrect signal amplitude levels may disturb the functionality and can damage the valve.

☞ The option 4...20 mA uses the "0 mA" condition as breakdown-information. This means the presence of an evaluable failure information if the input signal line is interrupted. In this case the actuator drive will be switched off. The drive will switch on when the input signal reaches a value of 3.8 mA, it switches off when the command falls below 3.6 mA. This determination follows the NAMUR-specification NE43. NAMUR is an association of users of process control technology.

Operation Manual

Wiring diagram of voltage command input +10...0...-10 V Code F0/M0 (6 + PE)

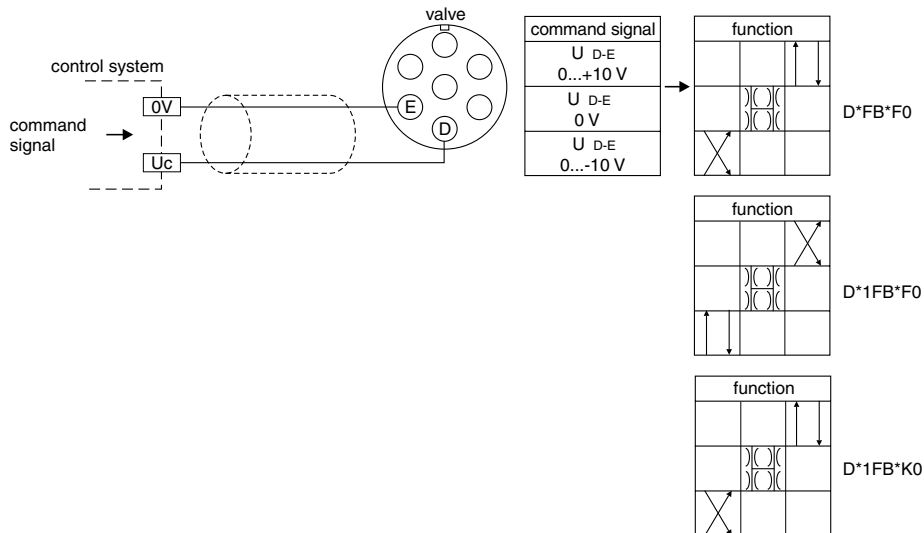

Wiring diagram of voltage command input +10...0...-10 V via potentiometer Code F0/M0 (6 + PE)

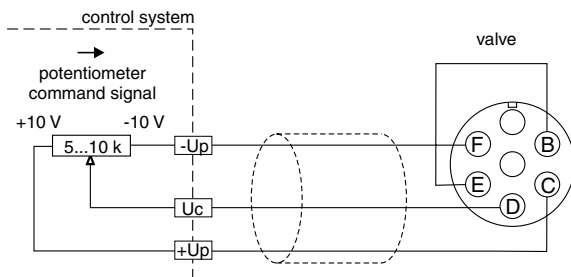

⚠ The external potentiometer is fed via the output "potentiometer supply". To prevent this output from overload, the resistance value of the potentiometer should be within a range of 5...10 kOhm. A nominal power rating of 0.1 W is sufficient.

**Wiring diagram of voltage command input +10...0...-10 V
Code W5 (11 + PE)**

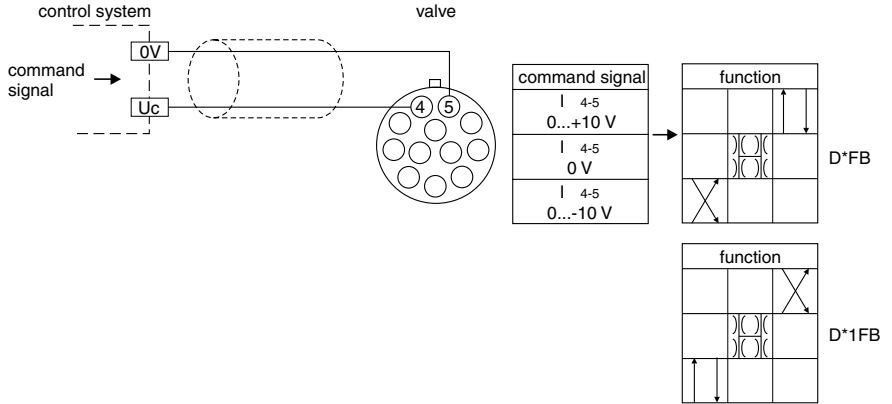

**Wiring diagram of voltage command input +10...0...-10 V via potentiometer
Code W5 (11 + PE)**

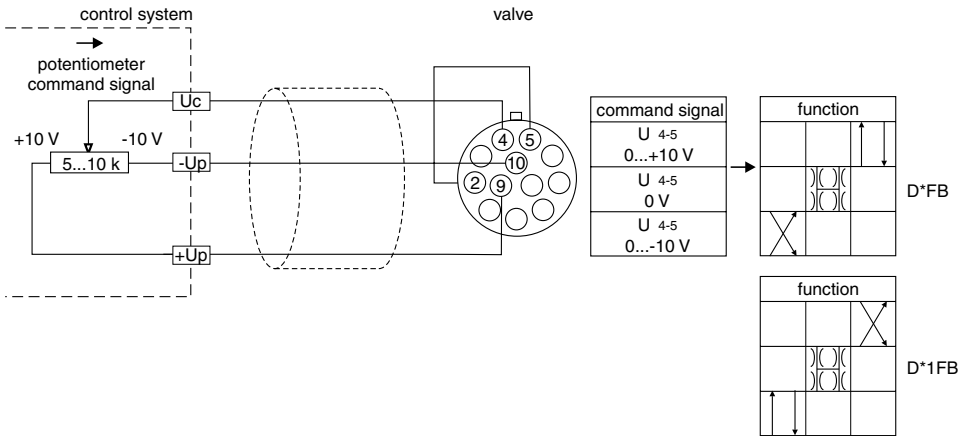

Wiring diagram of current command input +20...0...-20 mA Code G0 (6+PE)

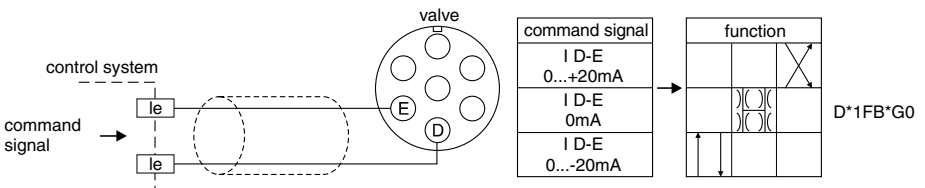

Wiring diagram of current command input 4...12...20 mA Code S0 (6 + PE)

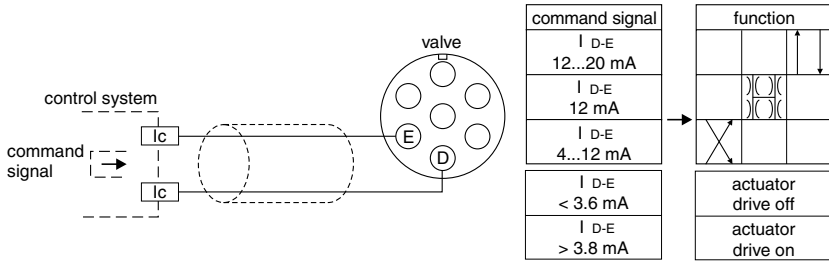

Wiring diagram of current command input 4...12...20 mA Code W5 (11 + PE)

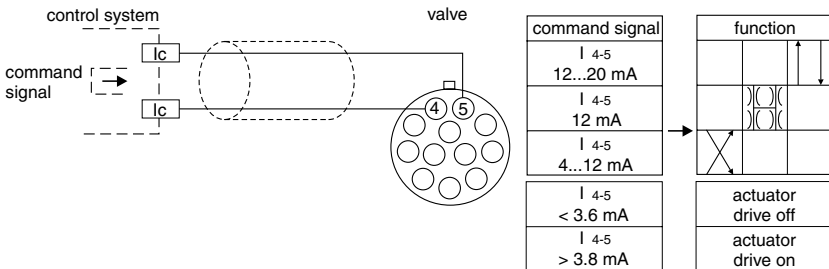

Recall channels for internal command preset

Up to six corresponding inputs are provided for the channel recall of internal command presets. The conjunction

options of the internal command channels may be selectable via the parameter E21. The following options are provided:

- priority dependent
- additive

At priority dependent channel recall the channel with the lowest numerical designation has priority against other

simultaneously addressed preset channels.

Example: Channels S1, S2, S3 are addressed. Channel S1 has priority, the corresponding internal command will be assessed as input signal.

The preset channels have priority against the analog signal input for the external command.

At additive channel recall the internal signal presets of the recall channels as well as a possible signal at the external signal input will be added. The sum of the signal values is limited at 100%.

Example 1: Channel S1 = +50%, channel S2 = +20%, external input signal = +5V (= +50%). The sum is +120%, in this case +100% input signal will be assessed.

Example 2: Channel S1 = +50%, channel S2 = +20%, external input signal = -5V (= -50%). The sum is +20%, in this case +20% input signal will be assessed.

The preset channels are switched through during the signal trigger at the dedicated inputs.

 More details are shown from the technical data.

 The channel recall signals needs to be filtered as well as free of inductive surges and modulations. To prevent malfunctions a high signal quality is recommended.

Wiring diagram of recall channels

Code W5 (11 + PE)

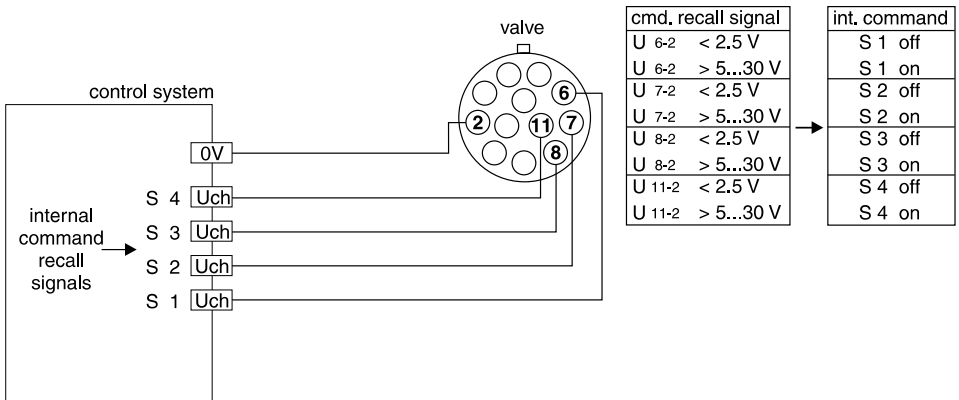

5. Operating Instructions

Basically the valve performs the task of converting a command signal into a proportional spool stroke with the highest possible dynamic. For these purposes the input value will be electronically processed and provides via a power amplifier stage the required current for the valve solenoid.

ProPxD parameterizing software:

The ProPxD software permits comfortable parameter setting for the module electronic. Via the clearly arranged entry mask the parameters can be noticed and modified. Storage of complete parameter sets to floppy or hard disk is possible as well as printout or record as a text file for further documentation. Stored parameter sets may be loaded anytime and transmitted to other valves. Inside the electronic a nonvolatile memory stores the data with the option for recalling or modification.

Features

- comfortable editing of all parameters
- depiction and documentation of parameter sets
- storage and loading of optimized parameter adjustments
- executable with all actual Windows® operating systems from Windows® 95 upwards
- plain communication between PC and electronic via serial interface RS232.

Comfortable interface, see Parker freeware available from infohcd@parker.com.

ProPxD screenshot

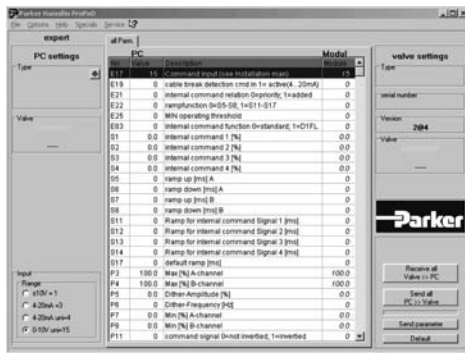

Hardware requirements

- PC with operating system from Windows® 95 upwards
- Interface RS232
- display resolution min. 800 x 600
- connection cable between PC and electronic module
- storage requirement approx. 4 MB

☞ It is recommended to select "small fonts" at the display setting, otherwise distortion of the display may occur.

Cable Specification

The connection of the valve electronic to a PC requires a special cable. It may be ordered under code 40982923. The cable has to be inserted between an unused serial port COM1 or COM2 of the PC and the 5pole socket connector of the valve electronic (parametrizing connector).

☞ Before connecting of the parametrizing cable a cover plug has to be removed from the electronic housing.

⚠ Attention! The valve electronic provides no USB interface, but can only be parametrized via an RS232 - connection. Therefore the usage of USB standard cables is permitted and may result in damaging of valve resp. PC.

Parametrizing connection



cover plug
parametrizing connection

Parametrizing cable 40982923

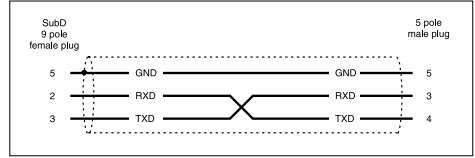

PC side connection

valve side connection



The cover plug has to be re-installed after completion of the parametrizing work.

Program installation

Please check before installation if the above hardware requirements are met. If your PC has already stored an older version of the “ProPxD” program, it has to be deinstalled by using the Windows® - system control feature.

Program installation sequence:

- terminate the execution of other programs
- insert ProPxD-software CD
- execute the file “setup.exe”
- follow the instructions on the screen

Answer the question, if an older version should be overwritten, with “ok”. During the installation you may change destination drive resp. installation path, if needed (i.e. if the storage space on drive “c” is not sufficient).

Please answer also “ok” if at the end of the installation the program reports any system information. After successful installation the desktop display shows the ProPxD icon for starting the program.

Software Operating

Brief instruction for first startup:

- Connect the valve electronic to the supply voltage.
- Connect the valve electronic to a PC via the parametrizing cable.
- Click on the ProPxD icon to start the operating program.
- After displaying the program resp. data base version a program window opens and the connected valve will be automatically identified (possibly a manual identification via the button “Receive all” is necessary).
- Select the desired version via the menu “Options/Optionen” with the menu item “Language/Sprache”.
- The valve specific default parameters are already available within the parameter table.
- Individual parameters may be selected via mouse or the arrow buttons at the center of the program screen.

- Parameter changes are possible via mouse or the arrow buttons on the bottom left within the program screen, also the parameter values may be edited via the keyboard.
- Modified parameters will be stored via the “Enter” key or via the button “Update list”.
- After completing of all modifications, the entire parameter set may be transmitted to the valve via the button “send all”, also the parameters will be nonvolatile stored.
- The chosen parameters may be optionally stored on the PC via the “File”-menu with the menu item “Save as”, data retrieving is always possible via the function “Load out of database”

Extended functions:

The user software is shared into 2 parameter ranges:

- basic mode
- expert mode

For normal startup the basic mode is absolutely sufficient. It permits the setting of all **application** specific parameters to match the valve function with the task setting.

In case of special applications the valve parameters may be adapted via the expert mode.

The operating mode may be selected from the “Options”- menu and remains after terminating and restart of the program.



Changing of expert parameters is only permitted for qualified personnel. Incorrect settings may lead to malfunction! In case of parameter changes shut the drive down!

To prevent an unauthorized access for the expert mode, a pass word is requested. The name is “parker” and cannot be changed. Thus additionally to the button “Default” for loading of the default parameters, the button “Send parameter” appears in the “Expert”-operating mode. This button transmits only the setting of one single parameter to the connected valve. Thus a quick tuning of single parameters is permitted during the setup.

 A horizontal bar graph readout between the communication buttons shows the data transfer state.

 Because the ProPxD program has also offline (i.e. without connection to the valve) functionality, a manual pre-selection of the parameters is possible. After selection of the valve type via the menu “Options” the parameters may be set and stored for later transmission. Note the design series while selection of the valve!

The “File” menu provides the functions “Printer setup”, “Print preview” and “Print”. The print preview includes the option for parameter set storage as text file (format .txt) prior to further processing. The “Options” menu provides also the selection of the RS232 interface port via the menu item “Port”. Via the menu item “Load out of database” previously stored parameter sets may be loaded.

Adjustment parameters

The available parameters may be divided into multiple groups and are characterized by different letters:

S-parameters

P-parameters

E-parameters

Parameter overview for basic mode

Parameter	Description	Unit	Parameter Range		Default Setting	Comment
			from	up to		
S1	internal Sollwert S1	%	-100	100	0.0	code W5 only
S2	internal Sollwert S2	%	-100	100	0.0	
S3	internal Sollwert S3	%	-100	100	0.0	
S4	internal Sollwert S4	%	-100	100	0.0	
S5	ramp accel. channel A	ms	0	32500	0	
S6	ramp decel. channel A	ms	0	32500	0	
S7	ramp accel. channel B	ms	0	32500	0	
S8	ramp decel. channel B	ms	0	32500	0	
P3	MAX channel A	%	50.0	100.0	100.0	
P4	MAX channel B	%	50.0	100.0	100.0	
P7	MIN channel A	%	0.0	50.0	0.0	
P8	MIN channel B	%	0.0	50.0	0.0	
P11	polarity command	-	0	1	0	
E17	option command	-	1 = ±10V 3 = 4-20mA		1 = ±10V	code W5 only
E19	cable break detection command	-	0	0 = ±10V 1 = 4-20mA	0 = +/-10V	codes S0 & W5 only
E25	MIN operating threshold	-	0 = 1% 1 = 0.01%		0 = 1%	

Individual Description of Basic Parameters

S1 command signal S1	Adjustment of the internal command signal channel S1. To attenuate of an external accessible command signal.
S2 command signal S2	Adjustment of the internal command signal channel S2. To attenuate of an external accessible command signal.
S3 command signal S3	Adjustment of the internal command signal channel S3. To attenuate of an external accessible command signal.
S4 command signal S4	Adjustment of the internal command signal channel S4. To attenuate of an external accessible command signal.
S5 ramp accel. channel A	Adjustment of ramp rate for increasing of the positive signal polarity. To avoid switching noise.
S6 ramp decel. channel A	Adjustment of ramp rate for decreasing of the positive signal polarity. To avoid switching noise.
S7 ramp accel. channel B	Adjustment of ramp rate for increasing of the negative signal polarity. To avoid switching noise.
S8 ramp decel. channel B	Adjustment of ramp rate for decreasing of the negative signal polarity. To avoid switching noise.
P3 MAX +	Adjustment of maximum signal span for positive output signal. To match the command signal span to the valve operating range.
P4 MAX -	Adjustment of maximum signal span for negative output signal. To match the command signal span to the valve operating range.
P7 MIN +	Adjustment for positive output signal step at 0,1% command signal. To compensate for the overlap of the valve spool.
P8 MIN -	Adjustment for negative output signal step at 0,1% command signal. To compensate for the overlap of the valve spool.
P11 command signal polarity	Adjustment of the command signal polarity. To match the command signal polarity to the valve operating direction.
E17 type of command signal device	Adjustment of the command signal option. To match the command signal input to the input signal mode.
E19 cable break detection command	Adjustment of the operating mode for the command cable break detection. To turn on resp. off of the cable break detection of the command signal at a selected command signal option of 4...20 mA.
E25 MIN operating threshold	Adjustment of the MIN operating threshold. To match the response sensitivity for the MIN-stroke step.

Parameter overview for expert mode

Parameter	Description	Unit	Parameter Range		Default Setting	Comment
			from	up to		
S11	ramp for int. command S1	ms	0	32500	0	
S12	ramp for int. command S2	ms	0	32500	0	
S13	ramp for int. command S3	ms	0	32500	0	
S14	ramp for int. command S4	ms	0	32500	0	
S17	default ramp	ms	0	32500	0	
P5	dither amplitude	%	0	10.0	0	
P6	dither frequency	Hz	0	300	0	
E21	option internal command signal conjunction	–	0 = priority dependent 1 = additive		0 = priority dependent	
E22	int. command signal ramp function	–	0 = quadrant dependent (S5...8) 1 = int. command depend. (S11...14)		0 = quadrant dependent	Code W5 only
E83	int. command signal functionality	–	0 = standard 1 = special option DFL		0 = standard	

Individual Description of Expert Parameters

S11 ramp for internal command signal 1	Adjustment of the ramp rate for the internal command signal channel S1. To avoid switching noise.
S12 ramp for internal command signal 2	Adjustment of the ramp rate for the internal command signal channel S2. To avoid switching noise.
S13 ramp for internal command signal 3	Adjustment of the ramp rate for the internal command signal channel S3. To avoid switching noise.
S14 ramp for internal command signal 4	Adjustment of the ramp rate for the internal command signal channel S4. To avoid switching noise.
S17 default ramp	Adjustment of the ramp rate for the default ramp. To avoid switching noise.
P5 dither amplitude	Adjustment of dither amplitude. To reduce the influence of solenoid friction.
P6 dither frequency	Adjustment of dither frequency. To match the dither signal to the valve dynamic.
E21 internal command signal conjunction	Adjustment of the conjunction for the internal command signals. To match the command signal logic.
E22 internal command signal ramp function	Adjustment of the ramp function for the internal command signals. To match the ramp functionality.
E83 internal command signal functionality	Adjustment of the functionality for the internal command signals. To match for the special option DFL.

Error messages

Malfunctions when using the ProPxD software program will be indicated via appropriate failure messages.

Failure messages and corrective actions:

Failure message	Description/corrective action
The Com Port is not available!	Terminate the other program, or quit the message and select another RS-232 port via the menu "Options > Port". Afterwards reconnect the parametrizing cable.
Unable to open COM port	Com port is not available. Quit the message and select another RS-232 port via the menu "Options > Port". Afterwards reconnect the parametrizing cable.
There is no module/valve connected or the communication is disturbed! Please check also the interface!	No data exchange possible. Either the electronic has been removed, the port is mismatched, or the connection will be disturbed by strong electrical fields. Check if the Com port is set for "9600, 8, 1. none, none" via the menu "Options > Port".
Wrong password	Retype the password, notice the exact spelling (case sensitivity).
Wrong input	An invalid character or a value outside the permitted range has been used at parameter entry.
Keep the entered parameters?	During parameter loading from the electronics memory the preset parameters from the left hand screen display may be rejected or maintained.
The chosen module/valve isn't the same as the connected hardware. Attention! Unsaved parameters will be lost.	In principle, parameters dedicated to a type which deviates from the connected valve may be edited. However, for data transmitting the correct valve has to be connected. If parameters will be loaded from a valve which deviates from the selected one, the parameters from the left hand side screen display of the program will be overwritten.
The chosen hardware isn't the same as the connected module/valve.	The wrong valve type has been selected from the database, afterwards the function "send all" has been executed.
Attention! Factory settings will be changed! Transmit anyhow?	Default parameters has been read out from the database instead from the valve via the function "receive all".
file name.pxd already exists. Do you want to replace the file?	The file name already exists within the indicated directory. Select another name, another directory or overwrite the existing file with "OK".

Air Bleeding of Hydraulic System

During initial startup, after an oil change as well as after the opening of lines or valves the hydraulic system must be air bled. Air in the hydraulic system is very disadvantageous and therefore undesirable for the control system. The pipeline network is vented at its highest point. The fitting may be loosened a little so that the air can escape with only a small amount of oil loss. When the oil is no longer foaming, the fitting is re-tightened. Afterwards all functions are run through, one after the other, in no-load operation with low pressure and with full cylinder stroke. Afterwards the system should be vented once more.

 After air bleeding the oil level in the tank must be checked, and refilled as necessary!

Filter

The function and lifetime of the valve are strongly affected by the cleanliness of the fluid.

 Dirt is the greatest enemy of the hydraulic system!

There are three important sources of dirt to watch for:

- contamination arising during installation
- contamination arising during operation, friction wear
- impurities from the environment

Basically a purity level class of 7 acc. NAS 1638 is required.

 Pay attention to maintenance details!

Flushing

It is recommended to flush the long pipelines by short circuiting the pressure and return lines, especially for large, central pressure oil stations. This prevents the installation dirt from entering the valve.

6. Maintenance



Service work may only be carried out by qualified personnel. Detailed knowledge of the machine functions concerning switching on and off as well as of the required safety relevant technical tasks is required!

Periodical maintenance is essential for the longevity of the system and guarantees reliability and availability. The following properties of the system has to be checked in continuous short time intervals:

- oil level in the tank
- max. working temperature
- condition of the pressure fluid (visual inspection, colour and smell of hydraulic fluid)
- working pressure levels
- gas pre-load pressure on the pressure accumulator
- leakage on all system components
- condition of filter elements
- condition of hose lines
- cleanliness of components

After a certain operating duration a change of the hydraulic fluid is required. The frequency of change depends from the following circumstances:

- kind resp. grade of the pressure fluid
- filtering
- operating temperature and environmental conditions

7. Trouble Shooting

Basis of troubleshooting is always a systematic approach. At first the following questions have to be checked:

- Are there practical experiences with similar failures?
- Have system adjustments been changed?

Afterwards starting of troubleshooting by means of a priority list of the most likely reasons.

 For suspect of a sluggish spool the valve may be flushed with clean pressure fluid.

 Troubleshooting in a hydraulic system requires in either case a systematic approach. The work may exclusively be performed by qualified personnel, as it requires detailed knowledge about function and construction of the system. Reversals or disassemblings may not be taken imprudently! Prior to the works it has to be clarified, if the system has been operated properly until the failure occurred.

malfunction at hydraulic load runtime							
						- generally no function	
						- high frequent oscillation	
						- low frequent oscillation	
						- one way operation only	
						- speed variations at unchanging command	
						- different speeds depending on travel direction	
						- speed too low	
						- drifting without command	
						possible reasons for malfunction	corrective actions
x						hydraulic pump resp. motor defective	replace hydraulic pump resp. motor
x	x	x	x	x	x	drive overloaded	reduce pressure resp. speed, increase valve size
x	x	x	x	x	x	valve contaminated	clean pressure fluid, filter / flush valve
					x	hydraulic fluid too viscous / too cold	change fluid grade, provide operational temperature
x					x	too low oil level within tank	refill pressure fluid
					x	filter contaminated	clean resp. replace filter
x	x				x	supply voltage too low	keep supply voltage range
	x					supply voltage carries too much ripple	reduce ripple
x					x	command signal too low	increase command signal
	x					command signal carries too much ripple	reduce ripple
					x	dither signal amplitude too high	reduce parameter P5
					x	dither signal amplitude too low	increase parameter P5
x	x				x	central connector contact failure	clean contacts resp. replace connector
x						feed cable interrupted	fix feed cable
x	x	x	x	x	x	wiring sequence incorrect	correct wiring sequence
					x	feed cable without shielding	change cable grade
x ¹⁾						pilot flow configuration incorrect	correct pilot flow configuration

¹⁾ only for D*1FB

8. Accessories / Spare Parts

Accessories

The following accessories are available for the valve series D*FB/D*1FT:

D11FB:
bolt kit ordering code BK375
Code F0/M0/S0/G0:
female connector 6+PE ordering code 5004072
Code W5:
female connector 11+PE ordering code 5004711

D3FB:
bolt kit ordering code BK385
Code F0/M0/S0/G0:
female connector 6+PE ordering code 5004072
Code W5:
female connector 11+PE ordering code 5004711

D31FB:
bolt kit ordering code BK385
Code F0/M0/S0/G0:
female connector 6+PE ordering code 5004072
Code W5:
female connector 11+PE ordering code 5004711

D41FB:
bolt kit ordering code BK320
Code F0/M0/S0/G0:
female connector 6+PE ordering code 5004072
Code W5:
female connector 11+PE ordering code 5004711

D91FB:
bolt kit ordering code BK360
Code F0/M0/S0/G0:
female connector 6+PE ordering code 5004072
Code W5:
female connector 11+PE ordering code 5004711

D111FB:
bolt kit ordering code BK386
Code F0/M0/S0/G0:
female connector 6+PE ordering code 5004072
Code W5:
female connector 11+PE ordering code 5004711

Spare Parts

The following spare parts are available:

D1FB:
seal kit NBR ordering code SK-D1FB-N

D3FB:
seal kit NBR ordering code SK-D3FB-N

D31FB:
seal kit NBR ordering code SK-D31FTN

D41FB:
seal kit NBR ordering code SK-D41FTN

D91FB:
seal kit NBR ordering code SK-D91FTN

D111FB:
seal kit NBR ordering code SK-D111FTN



Kaarst, Germany: Parker Hannifin GmbH



Kaarst, Germany: Parker Hannifin GmbH

